

# EFIS737

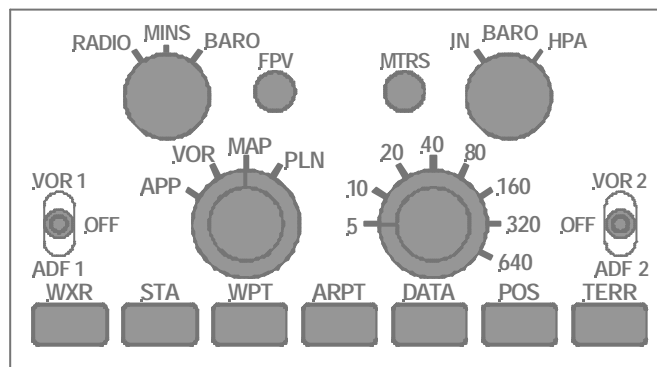

This manual is intended for Flight Simulator use only and may not be used in any real world aviation application. The authors are not responsible for any errors or omissions.

## FOREWORD

EFIS737 reproduce the EFIS selector located in the Boeing 737NG cockpit glareshield on both side of the MCP. EFIS737 may be considered an extension of the CPflight MCP737 and can operate only in conjunction with it. Because of the absence of detailed PFD and ND displays on default FS aircraft, the EFIS selector is useless with FS alone; and is dedicated to Project Magenta users ([www.projectmagenta.com](http://www.projectmagenta.com)).

Like MCP737, EFIS737 has reduced dimensions (about 85% scaled), and some small differences with respect to the original panel.

## IMPORTANT NOTE

To make the EFIS737 (and further add-on modules) function, the MCP737 firmware revision has to be at least 1.01. If you have a previous version installed in your MCP, you have to upgrade it to 1.01 or later. To upgrade the MCP firmware, download latest version at our web-site download page (<http://www.cpflight.com/sito/downloads/downloads.asp>). The file is in a compressed archive (zip format), unzip the files in a temporary folder and read carefully the enclosed "Readme" document. To check which firmware release you have on your MCP737, switch it on (see also "MCP737 Operations Manual") and look at IAS/MACH display during the start-up; the firmware release number appears for some seconds. The firmware upgrade procedure is fairly simple but also very delicate; we urge you to strictly following the procedure outlined in the readme document. If you feel unconfident or have any doubt, e-mail us at [support@cpflight.com](mailto:support@cpflight.com)

## HARDWARE INSTALLATION

EFIS737 is made for the many people that make their own "homebuilt" cockpits. For this reason it is designed for panel mounting. To insert the EFIS in your glareshield cut-out your panel as indicated in Figure 3 (at the bottom of manual) and keep space behind for cables and connectors to the MCP and to eventually other modules. Use the supplied "U" clamp to fix the EFIS; do not extremely tighten the nuts as you may damage the front panel.

## SETTING AND CONNECTIONS

*Note: Switch-off and disconnect power supply from the MCP before connecting any module.*

EFIS737 may operate as left or right selector; depending of setting it will have effect to the Project Magenta Captain or F/O displays and functions. To select left EFIS (Captain) insert the link "C" (Figure 1) to the CP position; obviously you will insert the link to the F/O position to make it work as First Officer EFIS selector.

Sockets for EFIS connection are on the back of panel. EFIS is arranged for daisy-chain connection so there are only two sockets (Figure 1 "A" and "B"); EFIS does not require an external power supply adapter since it is directly supplied by the MCP.

Connect a terminal of the enclosed 5 pole cable to one of the 5 pole sockets (it make no difference to which of two you connect) and the other side of cable to the AUX socket of the MCP. If you have other modules (for instance a second EFIS for the F/O side) you will connect it to the second socket of the EFIS and so on. If you have two EFIS selectors connected to the MCP pay attention not to set them to the same side (link C), since this may generate a communication conflict.

EFIS do not require any software configuration; you may reconnect MCP power supply and start it up, the MCP will scan the line and recognize your new EFIS selector/s.

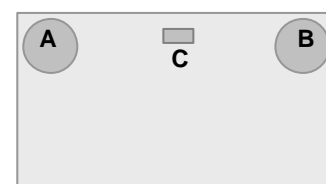

Figure 1 : Connectors and setting

## FUNCTIONING OVERVIEW

This section describes the EFIS737 functioning with Project Magenta. As with MCP737, EFIS panel form the hardware to set and select controls substituting keyboard and mouse; functioning is managed by Project Magenta software.

Some selections are affected by other aircraft settings (i.e. the "Data" key is useless if you do not have an active flight plan in the FMC/CDU). See also Project Magenta Operations Manual for more information about available commands. EFIS selector has a backlit panel; backlight is controlled by the MCP and will light up with it.

## Controls

Refer to the following Figure 2 for functioning description of each item. Descriptions may be referred to both Captain and/or F/O side:

*Note: CPflight EFIS selector sends commands to Project Magenta. Functions are managed by the software (see your Project Magenta Operations Manual). This means, any changes in the Project Magenta software will be reflected on EFIS functioning. The following descriptions refer to the Project Magenta functioning at the time of writing of this manual.*

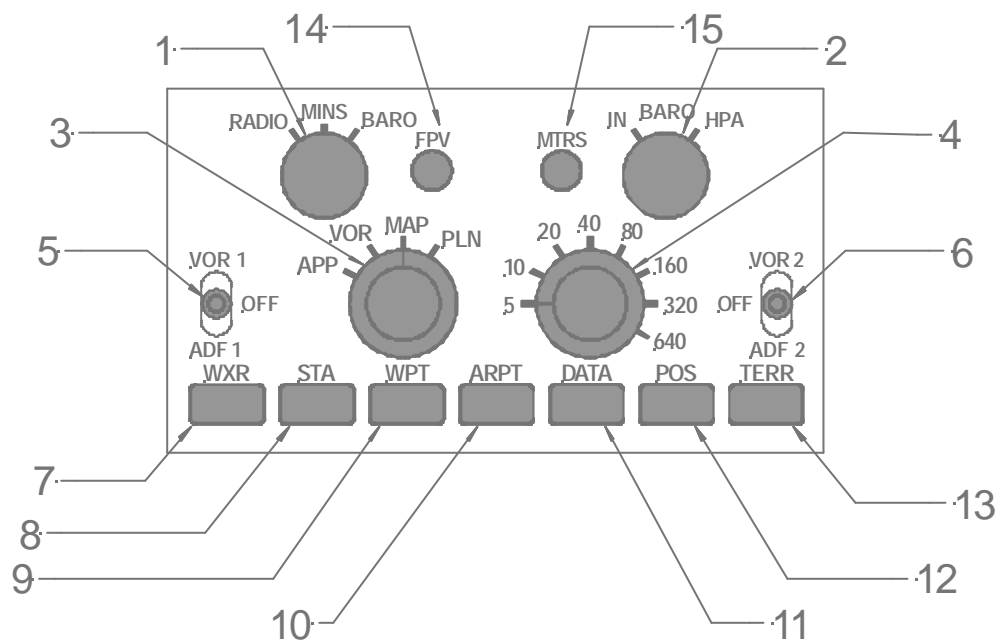

Figure 2: controls

1. **MINS SELECTOR:** has multiple functions:
  - ROTATE: increase/decrease the minimums altitude (Decision Height).
  - PUSH (for more than half second): resets the minimums altitude to the standard value (200) and blanks ALT alert if any.
  - PUSH AND LEFT ROTATE (within half second): selects radio altitude as minimums reference.
  - PUSH AND RIGHT ROTATE (within half second): selects barometric altitude as minimums reference
  
2. **BARO SELECTOR:** has multiple functions:
  - ROTATE: adjusts the altimeter barometric altitude setting
  - PUSH (for more than half second): resets the altimeter barometric altitude to the “standard setting” which is 29.92 inches Hg or 1013 HPA (see below)
  - PUSH AND LEFT ROTATE (within half second): selects Inches Hg reference units for the barometric altitude.
  - PUSH AND RIGHT ROTATE (within half second): selects HPA (hectopascals) reference units for the barometric altitude.
  
3. **ND MODE SELECTOR:**
  - ROTATE (4 positions): selects the indication on the Navigation Display to either APP, VOR, MAP or PLN mode.
  - PUSH: toggle the ND display between "Arc" and “Compass” modes (full compass rose)
  
4. **ND RANGE SELECTOR:**
  - ROTATE (8 positions): selects the range in nm (nautical miles) on the Navigation Display when in APP, VOR and MAP mode.
  - PUSH: toggle the traffic on Navigation Display (TFC)
  
5. **VOR1/ADF1 SWITCH:** toggles between VOR1 or ADF1 information and bearing on the ND; off when in center position.
  
6. **VOR2/ADF2 SWITCH:** toggles between VOR2 or ADF2 information and bearing on the ND; off when in center position.
  
7. to 13. Show/hide symbols on Navigation Display. Push shows information symbols while a second push removes them. Symbols visualization is affected by ND mode (MAP and CENTER MAP) and selected range; some functions are also affected by setting in Project Magenta ini files (see Project Magenta Operations Manual):
  
14. **FPV SWITCH:** toggle on/off flight path vector on PFD
  
15. **MTRS SWITCH:** show/hide altitude in meters on on PFD

## OVERVIEW

- Synthetic front panel silk screen coated with aluminum back cover
- 2 lever switches with three positions for VOR/ADF selection.
- 2 rotary encoders with push in switch for MINS and BARO selection and adjustment
- 4 position rotary switch with push in for display mode selection
- 8 position rotary switch with push in for ND range and TFC selection
- 7 pushbuttons for MAP data and symbol display
- 2 round pushbuttons for FPV and METER selection
- 8 bit Flash microcontroller.
- 2 DIN 5 pole socket for communication Interface to MCP737 and other modules.
- Supply: 4,5 to 5Vdc 80mA (powered by MCP737)
- Backlight panel
- 5 pole connection cable

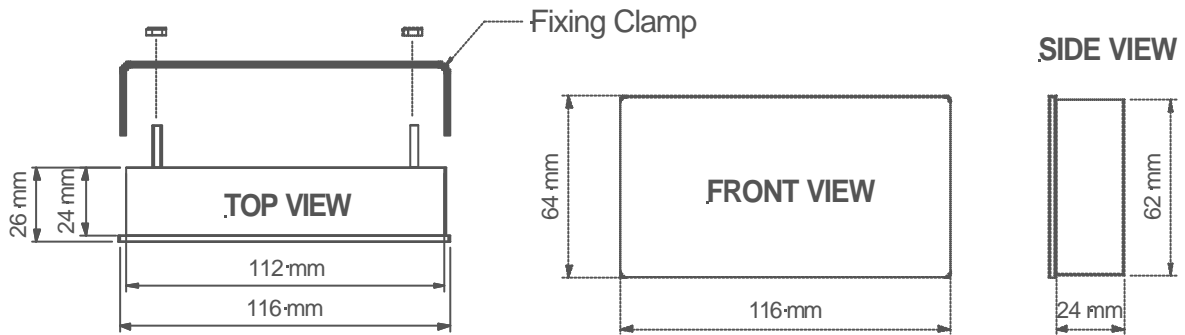

Figure 3: Dimensions

## LINKS/REFERENCES

Web site: <http://www.cpflight.com>  
 Info: [info@cpflight.com](mailto:info@cpflight.com)  
 Support: [support@cpflight.com](mailto:support@cpflight.com)

Project Magenta Web Site: <http://www.projectmagenta.com>

FSUIPC software and upgrade: <http://www.schiratti.com/dowson.html>